

Technical sheet

# **100 VJR**

Aerial Work Platforms Electric Vertical Mast

---

Capacities	Metric
Working height	9.85 m
Platform height	7.85 m
Horizontal outreach	3.15 m
Overhang	6.67 m
Pendular arm rotation (top/bottom)	70 ° / -70 °
Platform capacity	200 kg
Turret rotation	350 °
Number of people (inside/outside)	2 / 1
Weight and dimensions	
2.1 - Platform weight*	2650 kg
2.2 - Platform dimension (L x l)	1.11 x 0.93 m
b1 - Overall width	0.99 m
l1 - Overall length	2.80 m
h17 - Overall height	2 m
h20 - Floor height (access)	0.51 m
a7 - Counterweight offset (turret at 90°)	0.10 m
b13 - Inner turning radius	0.60 m
wa3 - Outer turning radius	2.09 m
m2 - Ground clearance at center of frame	0.10 m
2.16 - Plugs / stability bars ground clearance	0.03 m
y - Wheelbase	1.20 m
Performances	
Travel speed	4.50 km/h
Working speed	0.65 km/h
Gradeability	25 %
Permissible leveling	2 °
Tires	
Type of tires	No Marking
Dimensions	0.4 x 0.125
Drive wheels (front/rear)	0 / 2
Steering wheels (front/rear)	2 / 0
Braking wheels (front/rear)	0 / 2
Engine	
Electric pump	3 kW
Batteries (C5)	24 V / -
Integrated charger	24 V / 30 Ah
Miscellaneous	
Number of cycles (EARL)	29
Ground pressure	11.80 daN/cm <sup>2</sup>
Maximum available hydraulic pressure	140 bar
Capacity of hydraulic tank	22 l

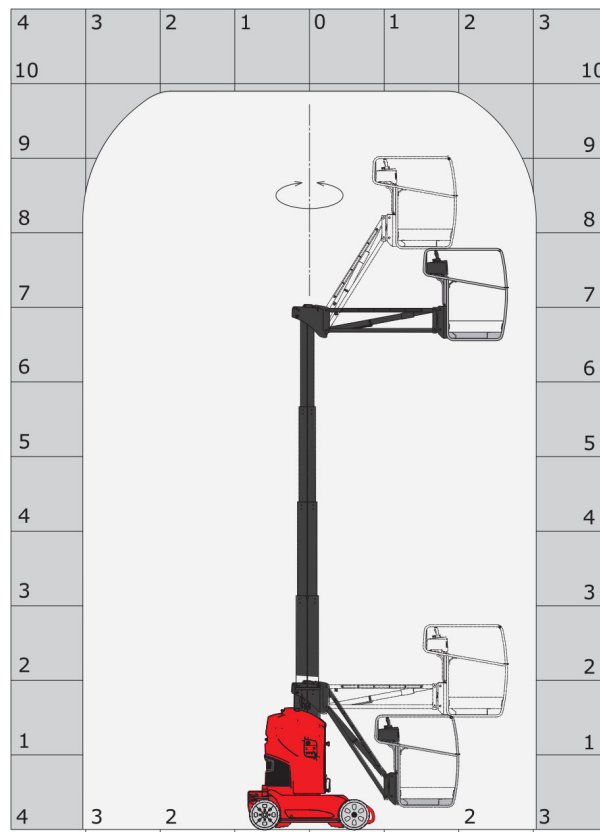

Dimensional drawing

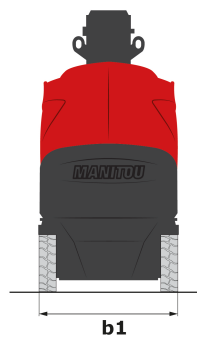
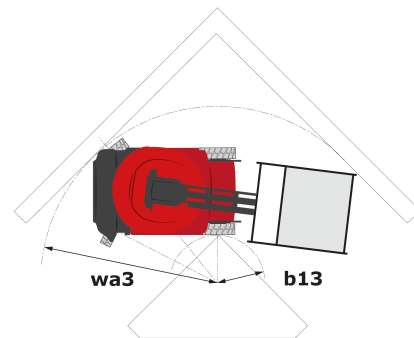
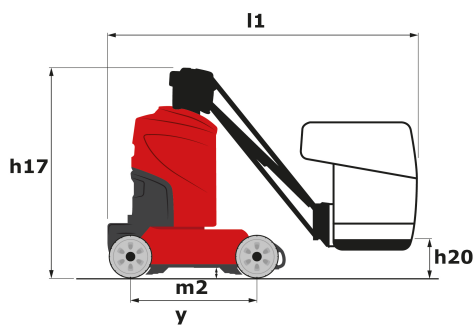

# Equipment

---

## Standard

Audible alarm and illuminated indicator lamp (leveling, overload, lowering)

Battery charge indicator lamp

CAN bus technology

Emergency stop button in platform and on frame

Fixed pothole protection

Horn in the platform

Hour meter

Integrated diagnostic assistance

Manual emergency lowering

Multi-voltage integrated charger

Negative-type braking on rear wheels

Non-marking rubber tires

Pendular arm

Platform with open-work floor

Proportional controls

Slings and securing rings

Tool box in platform

Traction battery

Fork pockets

Easy Manager

## Optional

110 or 230V plug with differential circuit-breaker

230V Predisposition

Air predisposition

Beep on every movement

Biodegradable oil

Centralized recharging of battery

Flashing Light

Initial verification report before putting into service

Maintenance-free battery

Extreme cold oil

Personalized paintwork

Safety harness

SMS : Safe Man System

Working headlight in platform



Siège Social  
430 rue de l'Aubinière - 44150 Ancenis Cedex - France  
Tel: +33(0)2 40 09 10 11 - Fax: +33 (0)2 40 09 10 97  
[www.manitou.com](http://www.manitou.com)



This brochure describes versions and configuration options for Manitou products which may be fitted with different equipment. The equipment described in this brochure may be standard, optional or not available depending on version. Manitou reserves the right to change the specifications shown and described at any time and without prior warning. The manufacturer is not liable for the specifications given. For more information, contact your Manitou dealer. Non-contractual document. Product descriptions may differ from actual products. List of specifications is not comprehensive. The logos and visual identity of the company are the property of Manitou and may not be used without authorisation. All rights reserved. The photos and diagrams contained in this brochure are provided for information only.

MANITOU BF SA - Limited company with board of directors - Share capital: 39,547,824 euros - 857 802 508 RCS Nantes